

## HTR Series Hydraulic Rack & Pinion Rotary Actuators

Market Segments and Applications	A48
Features	A49
Ordering Information	A50-A51
Specifications	A52-A53
Engineering Data	A54-A55
Dimensional Data	A56-A57
Options	
Cushions	A58
Stroke Adjusters	A59
Mounting	A60
Shaft	A61
Port Threads, Port Location	A62
Seals	A63
Proximity Sensors	A64
Feedback Packages	A64

**A****Rack & Pinion  
Actuators****HUB  
Series****LTR  
Series****HTR  
Series****M  
Series**

			Product Series					
			HUB	LTR	HTR	M	Tork-Mor	
			Market/Segment	Typical Application(s)				
<b>A</b>	Rack & Pinion Actuators	Aerospace	Water bomb, tank door actuation			●		
		Aggregate	Granite block rollover				●	
		Aluminum	Automation				●	
		Automation	Mounting, Processing, Flood gate actuation, End of arm tooling		●	●	●	●
		Automotive	Automation, Clamping, Tube bending				●	●
		Conveyor	Swing & rotate			●	●	●
		Entertaining	Pool gate actuation, Robotic joint motion					●
		Fluid Management & Flow Control	Power plants				●	●
		Industrial	Automation, Clamping					●
		Machine Builders	End of arm tooling				●	
		Marine/Offshore	Boomslewer, Submersible				●	●
		Mining	Mobile longhole drilling, Tunnel boring		●		●	●
		Mobile	Fire truck ladder rotation, Aerial lift basket, X-ray boom rotation, Forklift handling & storage, Refuse tippers		●	●	●	●
		Nuclear	Door actuation					●
		Oil & Gas	Process valve actuation		●		●	
		Oil Industry Machinery	Clamping, Lockout		●			●
		Paper & Pulp	Walking beam					●
		Plastics	Blow molding, Injection molding				●	●
		Rubber	Mixing				●	●
		Solar	Panel rotation				●	
		Space	Rocket launch tower					●
Steel & Casting	Ladle Tilt, Coil Box, Steel Booming, Pipe fabrication				●	●		
Testing Equipment	Flight Simulators, Cycle loading, Tensile test Machines				●	●		
Transportation	Bus wheelchair ramp			●				
Water Management			●		●			
Welding	Weld gun indexing, Clamping					●		

<b>A</b>	Rack & Pinion Actuators
HUB Series	
LTR Series	
HTR Series	
M Series	



A
Rack & Pinion Actuators
HUB Series
LTR Series
HTR Series
M Series

## HTR Series

### PISTON SEALS

Depending on actuator size, either dual lip seals made from abrasion resistant polyurethane or heavy duty, deep section Polypak seals made from Molythane for dependable service in most applications. Options: Fluorocarbon seals for certain synthetic fluids; and carboxilated nitrile seals for water based fluids. Piston seals can be inspected and replaced without disconnecting the load from the shaft. (Employ proper safety practices to prevent damage to people or equipment.)

### OPTIONAL CUSHIONS

If properly adjusted, cushions can serve as a braking device for most industrial loads and applications. The proven Parker "floating cushion bushing" serves as a high performance check valve for quick cushion get away and the needle valve can be adjusted to regulate the exhaust flow from the piston. Our design uses no springs or check valve seats that can fatigue or break under normal usage.

### WEAR BANDS

Filled PTFE bands (std) precisely position pistons and prevent side loading from scoring cylinder bores. High strength wear band options available.

**RACK & PINION** made from through hardened, high strength alloy steels for long and durable service life in most applications. Option: Case hardening.

### BRONZE RACK BEARING

reduces friction, wear and tear between the housing and the rack gear. Replaceable bronze bearing comes standard with HTR15 through HTR600 actuators. High strength bearing material options available.

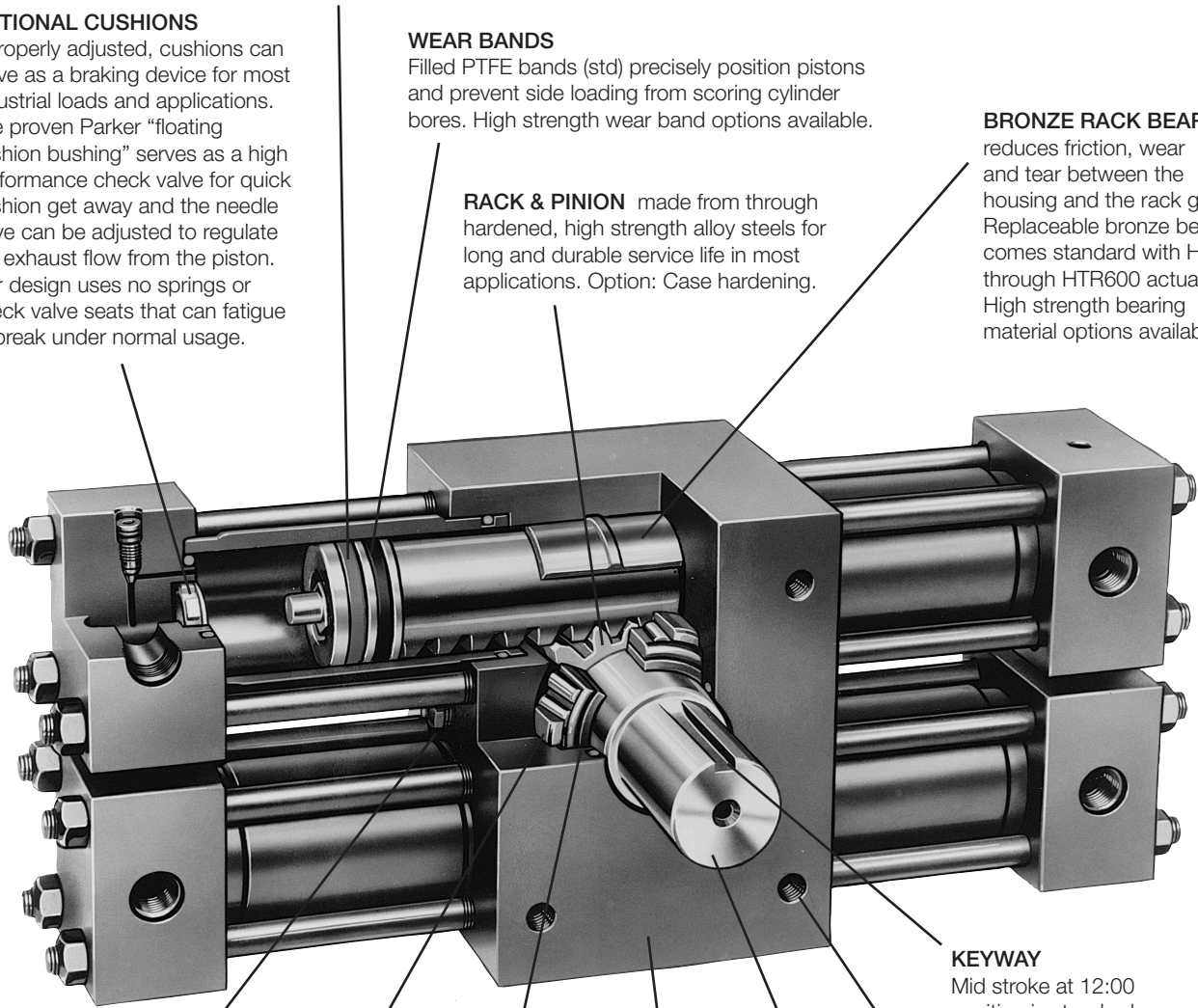

**RELIEF VALVE** is designed to prevent the housing from seeing pressure due to piston seal bypass. Seal kits are available.

**TAPERED ROLLER BEARINGS** are generously sized to support large external axial and radial loads applied to the shaft.

**PINION SEALS** Dual lobed seal of abrasion resistant materials seals effectively with minimum wear at dynamic conditions.

**HOUSING** The heavy, high strength, shock resistant, ductile iron housing serves as a firm base to drive large output torque requirements.

**KEYWAY** Mid stroke at 12:00 position is standard

**THREADED MOUNTING HOLES** Our standard mounting uses four bolt holes drilled and tapped on the front and back of the housing. Options: additional pilot ring or base mount.

**STANDARD MALE KEYED SHAFT** is made integral with the pinion gear and is suitable for most applications. Options: double male key, hollow bore keyed and spline shafts are available.

**Ordering information – Inch**

**A**  
 Rack & Pinion  
 Actuators

**HUB**  
 Series

**LTR**  
 Series

**HTR**  
 Series

**M**  
 Series

**HTR** **150** - **180** **3** **C** - **A** **B** **1** **1** **V** **J** - **C**

Size	
Torque output at 3000 psi	
Single rack units	
.9	900 in-lb
3.7	3,700 in-lb
5	5,000 in-lb
15	15,000 in-lb †
22	15,000 in-lb †
75	75,000 in-lb †
300	300,000 in-lb †
Double rack units	
1.8	1,800 in-lb
7.5	7,500 in-lb
10	10,000 in-lb
30	30,000 in-lb †
45	30,000 in-lb †
150	150,000 in-lb †
600	600,000 in-lb †

Degrees rotation	
090	90°
180	180°
360	360°
450	450°
Specify other rotations.	

Mounting style	
A	Face (standard)
B	Base mount
P	Pilot mount
X	Special

Shaft configuration	
A	Female keyed
B	Single male keyed (standard)
C	Double male keyed
D	Female 10B spline (Not available with HTR300/600)
E	Single male 10B spline (Not available with HTR300/600)
F	Double male 10B spline (Not available with HTR300/600)
J	Female involute spline (HTR300/600 only)
P	Single male involute spline (HTR300/600 only)
V	Double male involute spline (HTR300/600 only)
X	Special

Design series	
C	Current

Special options ‡	
Omit	Standard unit
Three-digit code assigned by factory when any "X" or "9" appears in the model number or when special options or features are required.	

Options (multiple choices allowed)	
H	Resolver feedback
J	Linear potentiometer
R	Bronze rack bearing
X	Other, special ‡

Seals	
Omit	Molythene/nitrile (standard)
V	Fluorocarbon
W	Carboxylated nitrile

Port location (see port location table)	
1	Side: Position 1 (standard)
2	Side: Position 2
3	Side: Position 3
4	Side: Position 4
5	End
9	Special

Port type	
1	SAE straight thread (standard)
2	NPTF
3	Flange
9	Special

Cushion	
Omit	None (standard)
1	CW rotation
2	CCW rotation
3	Both rotations
4	Four cushions **
8	High performance cushion **
9	Special

Stroke adjusters	
Omit	None
A	0-5° CW rotation^
B	0-5° CCW rotation^
C	0-5° both rotation^
D	0-30° CW rotation^^
E	0-30° CCW rotation^^
F	0-30° both rotations^^
X	Special

**Notes:**

- † Replaceable bronze rack bearing comes standard.
- \* Specify location.
- \*\* Double Rack Models Only. Use four cushions for existing applications only. For new applications, use option 8, High Performance Cushion. See options section for additional information.
- ^ Not available with End Ports. Standard 5° Stroke Adjusters and Standard Cushions available together on all units. Single rack units require additional "A" length.
- ^^ Not Available with End Ports or Cushions.

‡ Special options	
Other options such as air bleeds* and sensors must be ordered separately with detailed text.	

**Ordering information – Metric**

**HTR 150 - 180 3 C - D G 4 1 V J - C**

**Size**  
Torque output at 3000 psi

Single rack units	
.9	900 in-lb
3.7	3,700 in-lb
5	5,000 in-lb
15	15,000 in-lb <sup>†</sup>
22	15,000 in-lb <sup>†</sup>
75	75,000 in-lb <sup>†</sup>
300	300,000 in-lb <sup>†</sup>
Double rack units	
1.8	1,800 in-lb
7.5	7,500 in-lb
10	10,000 in-lb
30	30,000 in-lb <sup>†</sup>
45	30,000 in-lb <sup>†</sup>
150	150,000 in-lb <sup>†</sup>
600	600,000 in-lb <sup>†</sup>

**Degrees rotation**

090	90°
180	180°
360	360°
450	450°

Specify other rotations.

**Mounting style**

C	Face (standard)
D	Base mount
T	Pilot mount
X	Special

**Design series**

C	Current
---	---------

**Special options ‡**

Omit	Standard unit
Three-digit code assigned by factory when any "X" or "9" appears in the model number or when special options or features are required.	

**Shaft configuration**

G	Female keyed
H	Single male output, keyed (standard)
K	Double male output, keyed
L	Female spline (Not available with HTR300/600)
M	Single male spline (Not available with HTR300/600)
N	Double male spline (Not available with HTR300/600)
X	Special

**Special options**

H	Resolver feedback
J	Feedback potentiometer
R	Bronze rack bearing
X	Other, special ‡

**Cushion**

Omit	None (standard)
1	CW rotation
2	CCW rotation
3	Both rotations
8	High performance cushion **
9	Special

**Seals**

Omit	Molythane/nitrile (standard)
V	Fluorocarbon
W	Carboxylated nitrile

**Stroke adjusters**

Omit	None
A	0-5° CW rotation <sup>^</sup>
B	0-5° CCW rotation <sup>^</sup>
C	0-5° both rotation <sup>^</sup>
D	0-30° CW rotation <sup>^^</sup>
E	0-30° CCW rotation <sup>^^</sup>
F	0-30° both rotations <sup>^^</sup>
X	Special

**Port location**  
(see port location table)

1	Side: Position 1 (standard)
2	Side: Position 2
3	Side: Position 3
4	Side: Position 4
5	End
9	Special

**Port type**

4	BSPP (standard)
5	Metric to DIN 3852/1
6	Metric to ISO 6149/1
1	SAE straight thread
2	NPTF
3	Flange
9	Special

**Notes:**

- † Replaceable bronze rack bearing comes standard.
- \* Specify location.
- \*\* Double Rack Models Only. Use four cushions for existing applications only. For new applications, use option 8, High Performance Cushion.
- See options section for additional information.
- <sup>^</sup> Not available with End Ports. Standard 5° Stroke Adjusters and Standard Cushions available together on all units.
- Single rack units required additional "A" length.
- <sup>^^</sup> Not Available with End Ports or Cushions

**‡ Special options**

Other options such as air bleeds\* and sensors must be ordered separately with detailed text.

**A**  
 Rack & Pinion Actuators  
 HUB Series  
 LTR Series  
 HTR Series  
 M Series

The HTR Series rotary actuator incorporates many hydraulic and mechanical features that make this actuator both robust and ideal for the most demanding high production applications. These features include: high load capability tapered roller bearings; a chrome alloy steel rack and pinion gear set; a high strength ductile iron or steel housing; and proven Parker Hannifin cylinder components.

The HTR Series actuators have been successfully employed in automotive plant production machinery; machine tool equipment; plastics and rubber processing machinery; basic metals production machinery and in material handling machinery. The HTR Series can be employed as an integral machine component, where the actuator can simultaneously transmit torque and support the line shaft or the load. Such an arrangement allows for the elimination of one set of external support bearings.

Optional cushions can also be incorporated to decelerate external loads, thus eliminating the need for an external deceleration device such as shock absorbers or brakes. Additionally, machine installations can be simplified with the hollow shaft feature by eliminating additional coupling. This is achieved by means of a square shaft key or if needed the housing can be drilled and tapped to mount various brackets. For easy serviceability, the piston seals can be inspected and replaced while the actuator remains installed on the machinery.

- Hydraulic cushions to minimize noise, vibration shock and assist deceleration control
- Reed, Hall Effect or proximity switches for position sensing
- End-of-rotation stroke adjusters for load position control and accurate rotation adjustment
- Built-in meter out flow control valves with reverse flow check valves provide a neat package
- Three position option can be used with many special machine and material handling applications
- Rack and pinion design provides excellent efficiency characteristics (90-95%) and minimizes HPU Size
- Minimal Heat Build Up, Limits Need for Heat Exchanger Large Hollow Gears Offer More Shaft Options
- HTR series are designed for Low Wear on dynamic seals and longer life
- Excellent in High Speed Production Applications

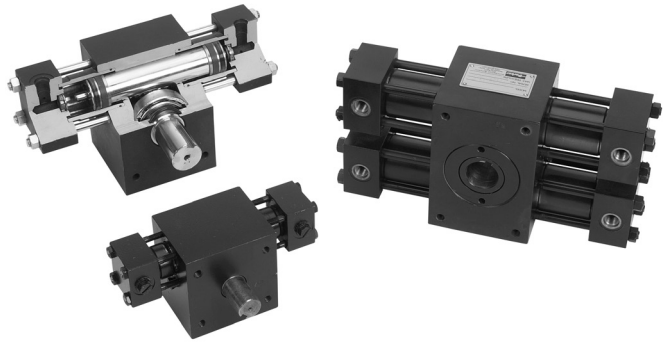

**Operating information**

Output torques @ 3000 PSI (207 bar):	900 in-lb to 600,000 in-lb (Larger output torques available upon request)
Maximum operating pressure: except HTR22/45:	3000 PSI (207 bar) non-shock 2000 PSI (138 bar) non-shock
Operating temperature range:	
Nitrile seals	-40°F to 180°F (-40°C to 82°C)
Fluorocarbon seals	-5°F to 250°F (-21°C to 121°C)
Standard rotations:	90°, 180°, 360°, 450°
Rotational tolerance:	-0°, +2°
Maximum breakaway pressure:	70 PSIG (4.8 bar)
Mounting orientation:	Unrestricted
Standard timing:	Keyway in 12:00 position at midstroke
Recommended filtration:	ISO class 17/14 or better

<b>A</b>	<b>Rack &amp; Pinion Actuators</b>
<b>HUB</b>	<b>Series</b>
<b>LTR</b>	<b>Series</b>
<b>HTR</b>	<b>Series</b>
<b>M</b>	<b>Series</b>

Model		Maximum Pressure Rating, PSI (bar)	Actual output torque, in-lb (Nm) at specified pressure			Gear train rating durability <sup>(1)</sup>		Maximum angular backlash, minutes <sup>(4)</sup>	Standard rotation degrees	Displacement in <sup>3</sup> (cm <sup>3</sup> )	Standard unit weight, lb (kg)
Single rack	Double rack		1000 PSI (69 bar)	2000 PSI (138 bar)	3000 PSI (207 bar)	inch-lbf <sup>(2)</sup>	PSID <sup>(3)</sup>				
HTR.9		3000 (207)	300 (34)	600 (68)	900 (102)	400	1340	45	90	0.57 (9.3)	11 (5)
									180	1.13 (19)	14 (6)
									360	2.27 (37)	20 (9)
HTR1.8		3000 (207)	600 (68)	1200 (136)	1800 (203)	850	1420	45	90	1.13 (19)	16 (7)
									180	2.27 (37)	19 (9)
									360	4.53 (74)	25 (11)
HTR3.7		3000 (207)	1250 (141)	2500 (283)	3700 (418)	1570	1300	40	90	2.43 (40)	28 (13)
									180	4.86 (80)	31 (14)
									360	9.71 (159)	37 (17)
HTR7.5		3000 (207)	2500 (283)	5000 (565)	7500 (848)	3330	1350	40	90	4.86 (79)	35 (16)
									180	9.71 (159)	41 (19)
									360	19.4 (318)	53 (24)
HTR5		3000 (207)	1650 (186)	3300 (373)	5000 (565)	2700	1620	30	90	3.12 (51)	37 (17)
									180	6.25 (102)	39 (18)
									360	12.50 (205)	49 (22)
HTR10		3000 (207)	3300 (373)	6600 (746)	10000 (1130)	5725	1720	30	90	6.25 (102)	45 (20)
									180	12.50 (205)	54 (25)
									360	25.0 (410)	66 (30)
HTR15		3000 (207)	5000 (565)	10000 (1130)	15000 (1695)	9300	1860	25	90	8.9 (145)	55 (25)
									180	17.8 (291)	60 (27)
									360	36.5 (582)	70 (32)
HTR30		3000 (207)	10000 (1130)	20000 (2260)	30000 (3390)	19700	1970	25	90	17.8 (291)	89 (40)
									180	35.5 (582)	97 (44)
									360	71.0 (1164)	117 (53)
HTR22		2000 (138)	7500 (848)	15000 (1695)	—	9300	1240	25	90	13.9 (227)	60 (27)
									180	27.8 (455)	66 (30)
									360	55.5 (910)	79 (36)
HTR45		2000 (138)	15000 (1695)	30000 (3390)	—	19700	1320	25	90	27.8 (455)	98 (45)
									180	55.5 (910)	108 (49)
									360	111 (1819)	134 (61)
HTR75		3000 (207)	25000 (2825)	50000 (5650)	75000 (8475)	25000	1000	25	90	46 (754)	197 (90)
									180	92 (1508)	219 (100)
									360	184 (3016)	263 (120)
HTR150		3000 (207)	50000 (5650)	100000 (11300)	150000 (16950)	53000	1060	25	90	92 (1508)	321 (146)
									180	184 (3016)	367 (167)
									360	368 (6032)	454 (206)
HTR300		3000 (207)	100000 (11300)	200000 (22600)	300000 (33900)	125000	1250	20	90	178 (2913)	760 (345)
									180	355 (5827)	840 (382)
									360	711 (11653)	910 (414)
HTR600		3000 (207)	200000 (22600)	400000 (45200)	600000 (67800)	265000	1325	20	90	355 (5827)	1110 (505)
									180	711 (11653)	1260 (573)
									360	1422 (23290)	1560 (709)

**A**  
 Rack & Pinion Actuators  
 HUB Series  
 LTR Series  
 HTR Series  
 M Series

- The durability is defined as the capacity of the gear set to support the stated load without fatigue related gear surface damage. Use the durability ratings for high production duty of 1 million cycles and/or high speed applications (180° in less than three seconds or more than one cycle per minute).
- Durability rated output torque.
- Pressure differential between the inlet and outlet ports (non shock).
- To minimize backlash in the actuator, order a double rack a few degrees longer and add stroke adjusters.



**Kinetic Energy Capacity**

The energy values below assume drive pressure is maintained through cushion stroke.

**Single Rack Units with Single Set of Cushions (20°)**

Model	Kinetic Energy Rating (in-lb) of Cushion at Specified Drive Pressure*											
	0 PSI		500 PSI		1000 PSI		1500 PSI		2000 PSI		2500 PSI	
	Max.	Durability	Max.	Durability	Max.	Durability	Max.	Durability	Max.	Durability	Max.	Durability
HTR.9	314	140	262	140	209	140	157	140	105	105	52	52
HTR3.7	1309	548	1091	548	872	548	654	548	436	436	218	218
HTR5	1745	942	1454	942	1163	942	873	873	582	582	291	291
HTR22	5235	3246	4362	3246	3490	3246	2618	2618	1745	1745	872	872
HTR75	5235	3246	3926	3246	2618	2618	1309	1309	0	0	0	0
HTR75	26175	8725	21812	8725	17448	8725	13088	8725	8724	8724	4362	4362
HTR300	104700	43625	87247	43625	69793	43625	52350	43625	34897	34897	17449	17449

**Double Rack Units with Single Set of Cushions (20°)**

Model	Kinetic Energy Rating (in-lb) of Cushion at Specified Drive Pressure*											
	0 PSI		500 PSI		1000 PSI		1500 PSI		2000 PSI		2500 PSI	
	Max.	Durability	Max.	Durability	Max.	Durability	Max.	Durability	Max.	Durability	Max.	Durability
HTR.9	314	140	209	140	105	105	0	0	0	0	0	0
HTR3.7	1309	548	873	548	436	436	0	0	0	0	0	0
HTR5	1745	942	1163	942	582	582	0	0	0	0	0	0
HTR22	5235	3246	3490	3246	1745	1745	0	0	0	0	0	0
HTR75	5235	3246	2618	2618	0	0	0	0	0	0	0	0
HTR75	26175	8725	17450	8725	8727	8725	0	0	0	0	0	0
HTR300	104700	43625	69801	43625	34907	34907	0	0	0	0	0	0

**Double Rack Units with Double Set of Cushions (20°)\*\***

Model	Kinetic Energy Rating (in-lb) of Cushion at Specified Drive Pressure*											
	0 PSI		500 PSI		1000 PSI		1500 PSI		2000 PSI		2500 PSI	
	Max.	Durability	Max.	Durability	Max.	Durability	Max.	Durability	Max.	Durability	Max.	Durability
HTR.9	628	297	523	297	419	297	314	297	209	209	105	105
HTR3.7	2618	1162	2181	1162	1745	1162	1309	1162	872	872	436	436
HTR5	3490	1998	2908	1998	2326	1998	1745	1745	1163	1163	582	582
HTR22	10470	6875	8725	6875	6979	6875	5235	5235	3490	3490	1745	1745
HTR75	10470	6875	7853	6875	5235	5235	2618	2618	0	0	0	0
HTR75	52350	18497	43623	18497	34897	18497	26175	18497	17448	17448	8725	8725
HTR300	209400	92485	174493	92485	139586	92485	104700	92485	69793	69793	34899	34899

\* Must deduct work (energy) done to overcome potential energy effects of load. WPE = TPE x Θ, where Θ is in radians.

\*\* Extreme care must be exercised so that both cushions are adjusted equally for each direction or dangerous pressure intensification and gear train stresses could result. (Suggest high performance cushion option.)

**Cushion Deceleration Control**

The cushion causes the resisting torque that can be used to decelerate a rotational load. Please note the cushion has to provide enough resistance to control: drive torque caused by the hydraulic system pressure; plus the torque caused by gravity pulling on the rotational load; and the kinetic energy associated with the motion of the inertia load. Since the actuator's cushion has to be able to control the sum of all three torque factors, we suggest including cushion capacity as one of the actuator selection criteria.

It is strongly suggested that proportional valves be used instead of cushions to control (decelerate) high inertial loads. This provides the ability to reduce inlet pressure while generating deceleration pressure. It also allows for longer ramp times, thus increasing deceleration stroke.

**SUPPLEMENTAL INFORMATION  
 KINETIC ENERGY BASIC FORMULA**

$$KE = 1/2 J_m \omega^2$$

$$\omega = 0.0175 \times \frac{2\Theta_A + \Theta_C + 2\Theta_D}{\text{Rotation Time (sec.)}}$$

- where:  
 KE = Kinetic Energy (in-lb)  
 J<sub>m</sub> = Rotational Mass Moment of Inertia (in-lb-sec<sup>2</sup>)  
 See page A35 of LTR section for formulas.  
 ω = Peak Velocity (rad/sec)  
 (Assuming trapezoidal velocity profile)  
 Θ<sub>A</sub> = Acceleration Angle (deg)  
 Θ<sub>C</sub> = Constant Velocity Angle (deg)  
 Θ<sub>D</sub> = Deceleration Angle (deg)





**Bearing Load Capacities**

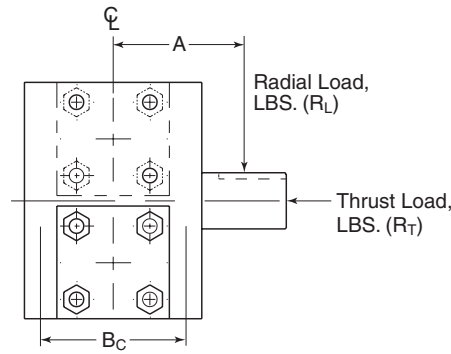

**Dynamic<sup>1</sup> Bearing Load Capacities vs. Operating Pressure**

Model	Radial Load (lbs.) $R_L$ (per bearing) @			Thrust Load (lbs.) $R_T$ @			Bearing Centers ( $B_c$ )	Overhung Moment (in-lb) $R_L \times (A+B_c/2)$ @		
	1000 PSID (69 bar)	2000 PSID (138 bar)	3000 PSID (207 bar)	1000 PSID (69 bar)	2000 PSID (138 bar)	3000 PSID (207 bar)		1000 PSID (69 bar)	2000 PSID (138 bar)	3000 PSID (207 bar)
HTR.9	3927	3824	3722	2690	2590	2490	0.62	2435	2371	2307
HTR1.8	4030	4030	4030	2790	2790	2790	0.62	2499	2499	2499
HTR3.7	6448	6146	5843	3610	3360	3120	1.06	6835	6514	6194
HTR7.5	6750	6750	6750	3830	3830	3830	1.06	7155	7155	7155
HTR5	8258	7956	7653	4240	4020	3810	1.02	8423	8115	7807
HTR10	8560	8560	8560	4460	4460	4460	1.02	8731	8731	8731
HTR15	14823	14286	13748	12300	11810	11330	1.83	27126	26143	25160
HTR30	15360	15360	15360	12780	12780	12780	1.83	28109	28109	28109
HTR22	14521	13681	na	12060	11330	na	1.83	26573	25037	na
HTR45	15360	15360	na	12780	12780	na	1.83	28109	28109	na
HTR75	20471	18322	16174	16540	14060	11570	3.99	81680	73106	64533
HTR150	22620	22620	22620	19020	19020	19020	3.99	90254	90254	90254
HTR300	38355	33520	28686	24090	19710	15340	5.95	228214	199447	170680
HTR600	43190	43190	43190	28460	28460	28460	5.95	256981	256981	256981

NOTES: 1. Static bearing load capacities = dynamic values x 1.5  
 2. Values listed are "Bearing" moment capacities. Standard male shaft sizes do not provide 4:1 design factor at these operating conditions. Larger shaft sizes are available. Consult factory for further details.

**Lubrication**

In general, low speed, high torque applications require class 5 or class 6 lubrication provisions. Our assemblers use TEXACO MOLYTEX EP(2) extreme pressure grease to lubricate our gear sets as our standard lubricant. The grease should be replaced with each major overhaul.

Some high cycle applications with an operational system pressure below 1000 PSIG (69 Bar) and with adequate mechanical shock control may successfully use the hydraulic fluid as the gear train lubricant. We can modify the housing by adding a case drain line to carry away excessive lubricant. Ensure the case drain connection is looped to ensure the housing remains filled with lubricant.

High performance applications that feature high pressure and high cycle rates should consider using an external lubrication circuit system to charge the gear set with clean, cool lubricant suitable for class 3 or 4 service. An SAE80 or SAE90 lubricant circulating system should be suitable. We can modify the housing for a lubrication circuit inlet and outlet. Ensure the plumbing is run in such a way the housing remains filled with lubricant.

**A**  
 Rack & Pinion Actuators  
 HUB Series  
 LTR Series  
 HTR Series  
 M Series

**HTR.9 thru HTR10 Single and Double Rack**

**Inch Units with Face Mount (A) and Male Keyed Shaft (B)**

**Metric Units with Face Mount (C) and Male Keyed Shaft (H)**

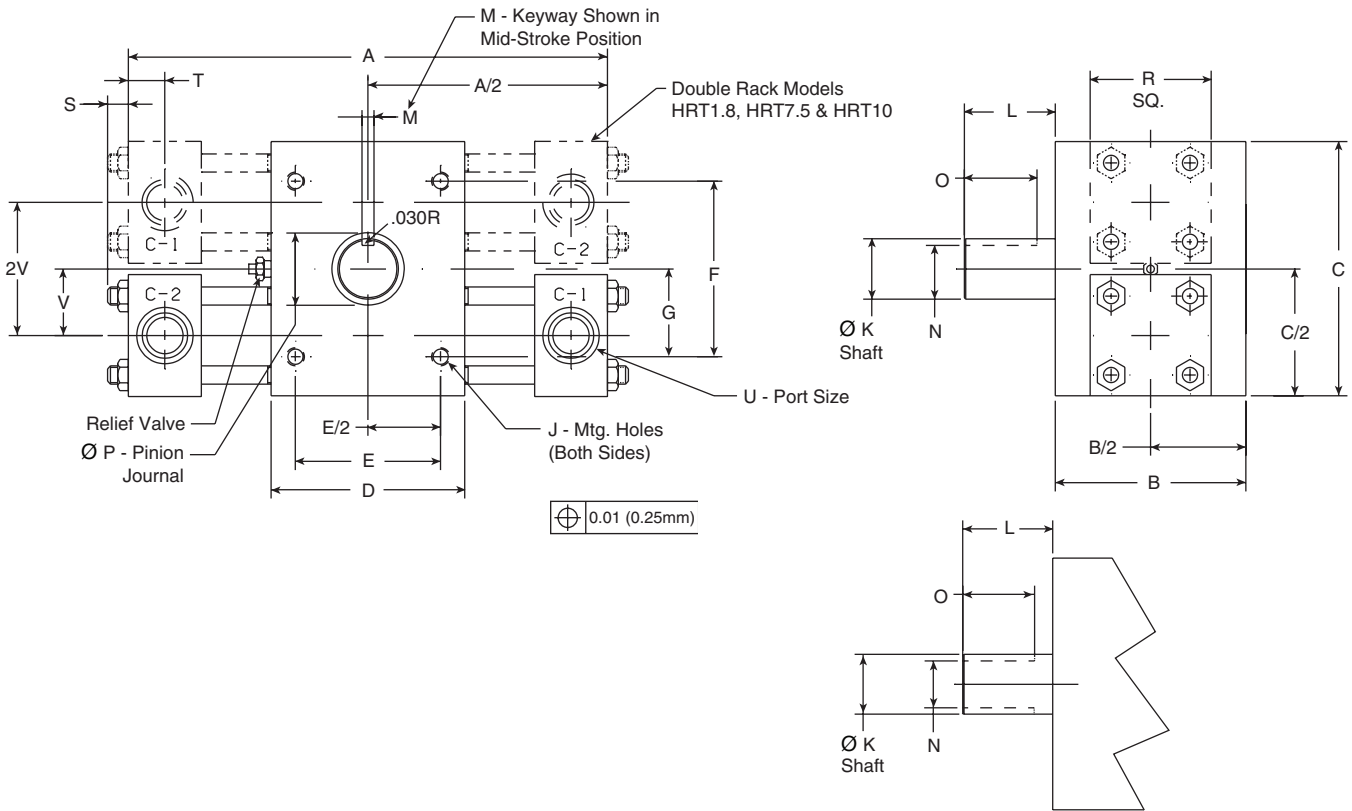

**Metric Keyed Shaft**

**Dimensions, Inch**

Model	Rotation Degrees	A	B	C	D	E	F	G	J	K <sup>†</sup>	L	M <sup>†</sup>	N <sup>†</sup>	O	P	R	S	T	U (SAE)	V
HTR.9 HTR1.8	90	7-1/4							5/16-18	.875		.250	.732						9/16-18 (#6)	0.94
	180	9-1/8	3	3-5/8	3-1/2	2.625	2.375	1.188	x	.874	1-5/16	.252	.722	1	1	1-3/4	.38	.50		
	360	12-7/8							1/2 DP											
HTR3.7 HTR7.5	90	10-1/8							3/8-16	1.250		.311	1.074						9/16-18 (#6)	1.38
	180	13-1/8	3-15/16	5-1/4	4	3.000	3.625	1.813	x	1.249	1-7/8	.312	1.064	1-1/2	1-1/2	2-1/2	.52	.72		
	360	18-1/4							9/16 DP											
HTR5 HTR10	90	11-3/8							3/8-16	1.750		.438	1.500						9/16-18 (#6)	1.63
	180	14-5/8	3-15/16	6	4	3.000	5.000	2.500	x	1.749	2-5/8	.440	1.490	2	1-25/32	2-1/2	.52	.72		
	360	22-1/8							9/16 DP											

**Dimensions, Metric (mm)**

Model	Rotation Degrees	A	B	C	D	E	F	G	J	K <sup>†</sup> +0, -.02	L	M <sup>†</sup> P9	N <sup>†</sup> +0, -.02	O	P	R	S	T	U BSPP/G	V
HTR.9 HTR1.8	90	184.2							M8			6	18.5	25.4	25.4	44.5	9.6	12.7	1/4	23.8
	180	231.8	76.2	92.1	88.9	70	60	30	x 1.25	22	33	6	18.5	25.4	25.4	44.5	9.6	12.7	1/4	23.8
	360	327.0							x 13 DP											
HTR3.7 HTR7.5	90	257.2							M10			8	20	38.1	38.1	63.5	13.3	18.3	1/4	34.9
	180	333.4	100.0	133.4	101.6	75	90	45	x 1.5	28	48	8	20	38.1	38.1	63.5	13.3	18.3	1/4	34.9
	360	463.6							x 16 DP											
HTR5 HTR10	90	288.9							M10			12	39	50.8	44.5	63.5	13.3	18.3	1/4	41.3
	180	371.5	100.0	152.4	101.6	75	125	62.5	x 1.5	44	66	12	39	50.8	44.5	63.5	13.3	18.3	1/4	41.3
	360	562.0							x 16 DP											

<sup>†</sup> Tolerance minimum and maximum



**HTR15 thru HTR600 Single and Double Rack**

**Inch Units with Face Mount (A) and Male Keyed Shaft (B)  
 Metric Units with Face Mount (C) and Male Keyed Shaft (H)**

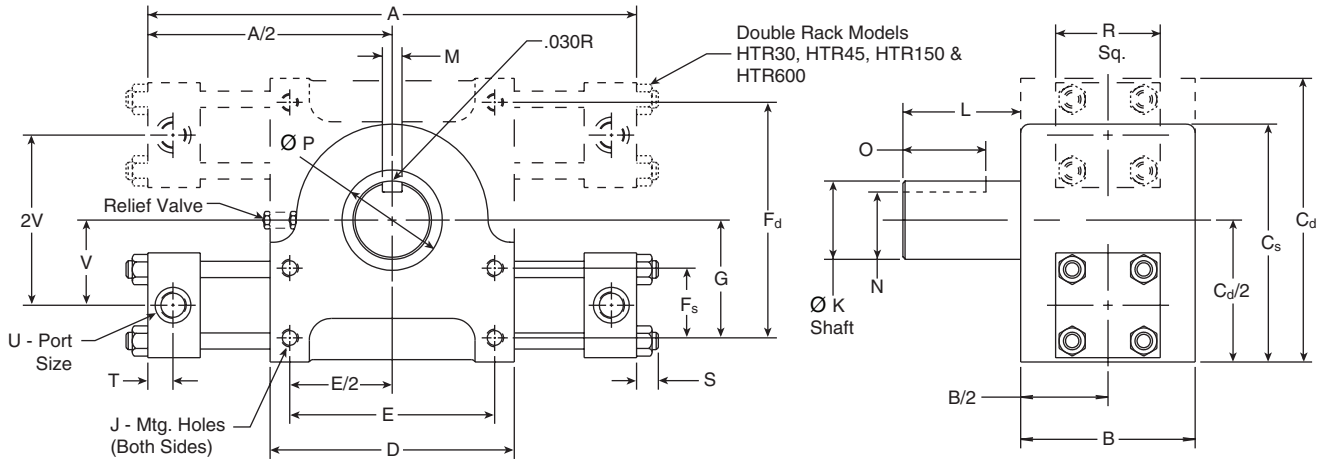

**Dimensions**

Model	Rotation Degrees	A (inch)	A (mm)
HTR15/30	90	16	406.4
	180	21-3/8	543.0
	360	32-1/8	816.0
HTR22/45	90	16-3/8	416.0
	180	21-3/4	552.5
	360	32-3/8	822.3
HTR75/150	90	20-1/4	514.4
	180	27-5/8	701.7
	360	42-1/4	1073.2
HTR300/600	90	31-1/4	793.8
	180	43-3/4	1111.3
	360	68-7/8	1749.4

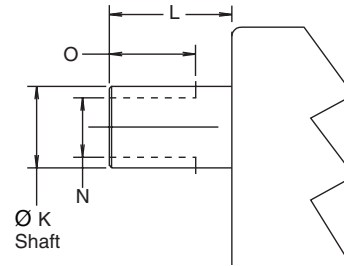

**Metric Keyed Shaft**

**Dimensions, Inch**

Model	B	Cd	Cs	D	E	Fd	Fs	G	J	K†	L	M†	N†	O	P	R	S	T	U (SAE)	V
HTR15	5	-	6-7/8	7	5.875	-	2.000	3.375	1/2-13 x 3/4 DP	2.250	3-3/8	.563	1.933	2-3/8	2-7/8	3	.67	.72	3/4-16 (#8)	2-7/16
HTR30		8-1/8	-			6.750	2.249													
HTR22	5	-	6-15/16	7	5.875	-	2.000	3.375	1/2-13 x 3/4 DP	2.250	3-3/8	.563	1.933	2-3/8	2-7/8	3-1/2	.67	.72	3/4-16 (#8)	2-7/16
HTR45		8-3/8	-			6.750	2.249													
HTR75	7-1/2	-	10	8-1/2	6.500	-	4.500	5.750	3/4-16 x 1-1/8 DP	3.000	4-1/2	.750	2.577	3-3/8	3-3/4	5	.82	.84	1-1/16-12 (#12)	3-1/2
HRT150		13	-			11.500	2.999													
HTR300	12	-	15-1/4	15-7/8	13.000	-	5.000	7.625	1-1/4-7 x 1-7/8 DP	5.000	7-1/2	1.250	4.296	6	6-1/2	7-1/2	1.22	1.25	1-5/16-12 (#16)	5-1/8
HTR600		18-3/4	-			13.500	4.999													

**Dimensions, Metric (Metric male and female shafts have 2 keyways)**

Model	B	Cd	Cs	D	E	Fd	Fs	G	J	K +0, -.02	L	M P9	N +0, -.02	O	P	R	S	T	U BSPP/G	V
HTR15	127.0	-	174.6	177.8	150	-	50	85	M12x1.75 x19 DP	54	86	16	42	60	73.0	76.2	17.0	18.3	1/2	61.9
HTR30		206.4	-			170	-													
HTR22	127.0	-	176.2	177.8	150	-	50	85	M12x1.75 x19 DP	54	86	16	42	60	73.0	88.9	17.0	18.3	1/2	61.9
HTR45		212.7	-			170	-													
HTR75	190.5	-	254.0	215.9	165	-	115	145	M20x2.5 x30 DP	76	115	22	58	85	95.3	127.0	20.7	21.3	3/4	88.9
HTR150		330.2	-			290	-													
HTR300	304.8	-	387.4	403.2	330	-	125	175	M30x3.5 x48 DP	125	190	32	103	152	165.1	190.5	31.0	31.8	1	130.2
HTR600		476.3	-			350	-													

† Tolerance minimum and maximum



**A**

**Rack & Pinion Actuators**

**HUB Series**

**LTR Series**

**HTR Series**

**M Series**

**Parker Pneumatic**

**Cushions (1, 2, 3, 4) \***

The standard cushion operates over the last 20° of rotation in either or both directions. A floating bushing ensures no binding of cushion spear. All cushions are fully adjustable.

For severe operating conditions high performance cushions should be fitted on double rack units. On double rack units with only two cushions, cushions are located on upper cylinders.

For double rack units where Option 4 (four cushions) is selected please take special care to make sure that adjacent cushions (ie both C-1 ports) are adjusted to the same cushion setting so as to ensure that both cushions are working together. An improper setting could result in one of the cushions not being utilized and thus result in premature gear train life or other damage to the unit.

\* For gear train durability, see table below.

**Standard Cushion Adjuster Needle Locations**

Port position	Cushion adjuster position
1	2
2	3
3	2
4**	3
5	2

\*\*Single rack only

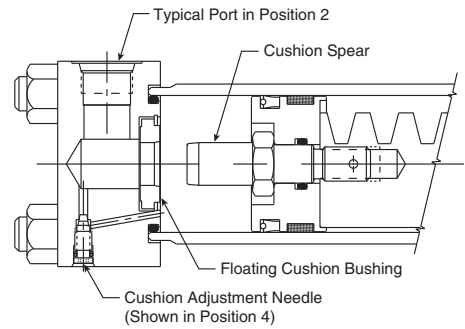

**Suggestions:** Use either Type 4 or Type 8 cushion option with HTR1.8, 7.5, 30, 45, 150 and 600 size actuators. Avoid Type 1, 2 or 3 cushions with double rack units. The use of proportional valves instead of cushions is recommended with high inertial loads.

**High Performance Cushion (8)**

(This option available with double rack units only)

By combining the output/exhaust flow from two cylinders, then routing it through a single cushion bushing and cushion adjuster, cushion performance is enhanced. The increased cushion flow results in better control, doubles the cushioning torque, and eliminates dangerous pressure intensification. This unique circuit also eliminates two pipe or tubing tees.

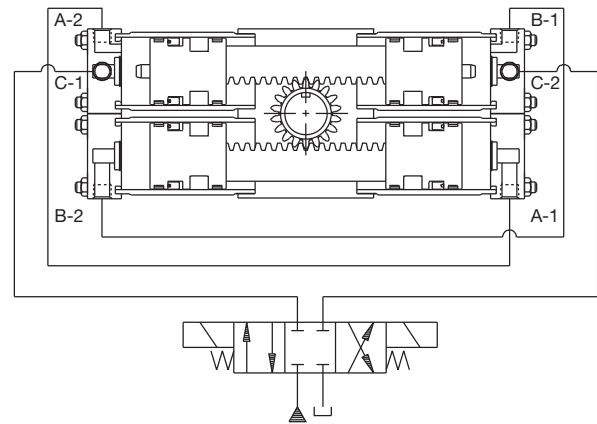

**Operation:**

The work ports of a standard directional valve are plumbed to ports C-1 and C-2. Port A-1 is plumbed directly to A-2, and port B-1 is plumbed to B-2. When pressure is applied to port C-1 (clockwise shaft rotation), fluid is also directed through line A to the other rack. Exhaust flow from B-1 through B-2 is directed through the cushion bushing and cushion adjustment. When the cushion spear closes off the main passage, total flow from both end caps is directed across one cushion adjustment needle, equalizing back pressure and improving performance. Alternatively, pressurizing C-2 and exhausting C-1 reverses the operation.

Work ports C-1, C-2 port position	Cushion adjustment position	Connection ports A-1, A-2 & B-1, B-2 port position
1	2	3
2	3	1
3	2	1
5	2	3

**Dimensional Information:**

Units are identical to standard double rack and pinion units, with the exception of porting location. The chart describes the location of the ports.

**Gear Set Durability**

The table to the right provides energy ratings based on gear train durability when using various cushion options for the HTR Series.

Model	Total energy capacity (in-lb)		Port to port ΔP (PSID)	
	Code 1,2,3	Code 8	Code 1,2,3	Code 8
HTR.9	140	—	1340	—
HTR1.8	140	297	670	1340
HTR3.7	548	—	1300	—
HTR7.5	548	1162	650	1300
HTR5	942	—	1620	—
HTR10	942	1998	810	1620
HTR15/22	3246	—	1860/1240	—
HTR30/45	3246	6875	930/620	1860/1240
HTR75	8725	—	1000	—
HTR150	8725	18497	500	1000
HTR300	43625	—	1250	—
HTR600	43625	92485	625	1250

**A**  
 Rack & Pinion Actuators  
 HUB Series  
 LTR Series  
 HTR Series  
 M Series



**Stroke Adjusters**

Fine control of the end of travel points of the rotary actuator can be obtained by specifying stroke adjusters. These operate by reducing the maximum travel of the actuator within preset limits of either 5° or 30° in each direction. Adjustment within this range is variable and may be carried out by the user. Several types of stroke adjusters are available as shown – the designs illustrated are suitable for applications requiring infrequent adjustment.

Limit the setup of stroke adjust to 1-2 adjustments. If frequent adjustments are required, consult factory.

**Stroke Adjusters and Cushions**

5° stroke adjusters may be combined with the cushioning devices shown. 30° stroke adjusters cannot be combined with cushions. The addition of stroke adjusters requires an increase in build length. On double rack units with cushions, the cushion is fitted to the upper rack and the stroke adjuster to the lower. The increase in build length, for both single and double rack units, is shown as dimension A in the table. Cushion performance may be reduced by the addition of a stroke adjuster. Please consult the factory in critical applications.

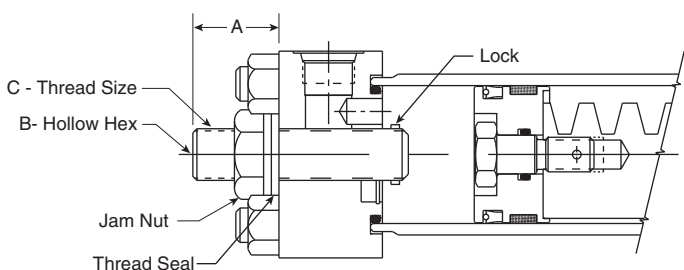

Lock limits unthreading from outside.  
**Caution:** damage to end cap may result if disassembled in this direction.

**Type I Stroke Adjusters, 5° and 30°**

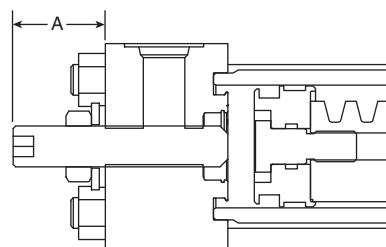

**Type II Stroke Adjusters, 5°**

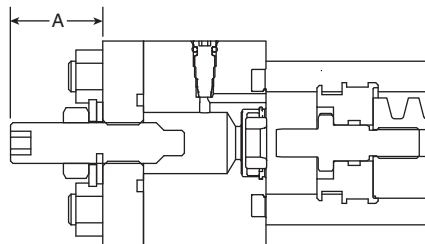

**A (max) – Increased build length**

Model	One (1) turn adj.	TYPE I 5° adjustment without cushioned end cap		TYPE II 5° adjustment with cushioned end cap		TYPE I 30° adjustment without cushioned end cap		B	C
		inch	mm	inch	mm	inch	mm		
HTR.9 HTR1.8	4.2°	.50	12.7	.88	22.4	.75	19.1	5/32	5/16 - 24 UNF
HTR3.7 HTR7.5	3.3°	.63	16	1.13	28.7	1.13	28.7	1/4	1/2 - 20 UNF
HTR5 HTR10	2.5°	.63	16	1.13	28.7	1.13	28.7	1/4	1/2 - 20 UNF
HTR15/30 HTR22/45	2.0°	.88	22.4	1.81	46	1.63	41.4	3/8	3/4 - 16 UNF
HTR75 HTR150	2.0°	2.56	65	3.75	95.3	3.56	90.4	15/16 Ext. Sq.	1-1/2 - 12 UNF
HTR300 HTR600		Consult Factory							

<b>A</b>	Rack & Pinion Actuators
	HUB Series
	LTR Series
	HTR Series
	M Series

**Parker Pneumatic**

**Base and Pilot Mounting**

HTR Series rotary actuators are available with the options of face, base, or pilot mounting styles to suit the requirements of different applications. Mounting dimensions for the face mounting styles are shown with other major dimensions on the previous pages. The equivalent dimensions for base and pilot mounting styles are shown in the tables below.

Model	Mounting Hole Bolt Size	Suggested Bolt Torque	Mounting Face Torque Limit*
HTR.9 HTR1.8	5/16-18 UN x 12 dp	126 in-lb	900 in-lb 1800 in-lb
HTR3.7 HTR7.5	3/8-16 UN x 9/16 dp	300 in-lb	3750 in-lb 7500 in-lb
HTR5 HTR10	3/8-16 UN x 9/16 dp	300 in-lb	7500 in-lb 10,000 in-lb
HTR15 HTR30	1/2-13 UN x 3/4 dp	60 ft-lb	15,000 in-lb 15,000 in-lb
HTR22 HTR45	1/2-13 UN x 3/4 dp	60 ft-lb	30,000 in-lb 30,000 in-lb
HTR75 HTR150	3/4-16 UN x 1-1/8 dp	160 ft-lb	63,500 in-lb 99,740 in-lb
HTR300 HTR600	1-1/4-7 UN x 1-7/8 dp	720 ft-lb	300,000 in-lb 600,000 in-lb

\*Without additional reinforcement.

**Mounting Options (B, D, P, T)**

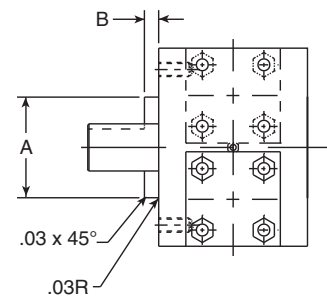
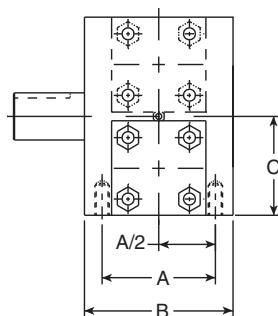
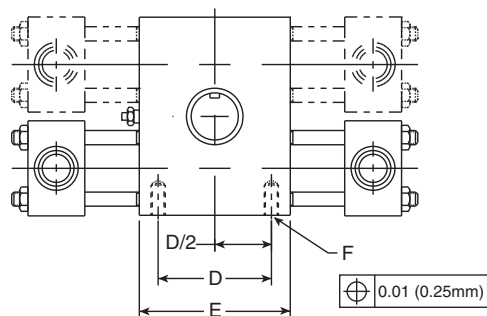

**Base Mounting, Inch (B)**

Model	A	B	C	D	E	F
HTR.9 HTR1.8	2.250	3	1.813	2.625	3-1/2	5/16-18 NC x 1/2 DP
HTR3.7 HTR7.5	3.000	3-15/16	2.625	3.000	4	3/8-16 NC x 9/16 DP
HTR5 HTR10	3.000	3-15/16	3.000	3.000	4	3/8-16 NC x 9/16 DP
HTR15/30 HTR22/45	3.875	5	4.063 4.188	5.875	7	1/2-13 NC x 3/4 DP
HTR75 HTR150	5.750	7-1/2	6.438	6.500	8-1/2	3/4-16 NF x 11/8 DP
HTR300 HTR600	9.500	12	9.375	13.000	15-7/8	1 1/4-7 NC x 17/8 DP

**Base Mounting, Metric\* (D)**

Model	A	B	C	D	E	F
HTR.9 HTR1.8	60	76.2	46.1	70	88.9	M8 x 1.25 x 13
HTR3.7 HTR7.5	75	100.0	66.7	75	101.6	M10 x 1.5 x 16
HTR5 HTR10	75	100.0	76.2	75	101.6	M10 x 1.5 x 16
HTR15/30 HTR22/45	100	127.0	103.2 106.4	150	177.8	M12 x 1.75 x 19
HTR75 HTR150	146	190.5	163.5	165	215.9	M20 x 2.5 x 30
HTR300 HTR600	240	304.8	238.2	330	403.2	M30 x 3.5 x 48

**Pilot Mounting, Inch (P), Metric (T)**

Model	Inch		Metric*	
	A	B	A	B
HTR.9 HTR1.8	1.875 1.873	1/4	47.63	6.5
HTR3.7 HTR7.5	2.625 2.623	1/4	66.68	6.5
HTR5 HTR10	2.875 2.873	1/4	73.03	6.5
HTR15/30 HTR22/45	4.250 4.248	3/8	107.95	10
HTR75 HTR150	5.500 5.498	3/8	139.67	10
HTR300 HTR600	8.750 8.748	1/2	225.25	12

\*Dimensions given in mm.



**Shaft Options**

**Single Male Keyed (B)**

Metric version (H) also available

Model	Torque, in-lb	Key Size	Suggested Key Material
HTR.9 / HTR1.8	1,800	1/4 x 1/4 x 1	C1018CR
HTR3.7 / HRT7.5	7,500	5/16 x 5/16 x 1-1/2	C1018CR
HTR5 / HTR10	10,000	7/16 x 7/16 x 2	C1018CR
HTR15 / HTR30	30,000	9/16 x 9/16 x 2-3/8	C1018CR
HTR22 / HTR45	30,000	9/16 x 9/16 x 2-3/8	C1018CR
HTR75 / HTR150	102,000	3/4 x 3/4 x 3-3/8	C1045CR
HTR300 / HTR600	475,000	1-1/4 x 1-1/4 x 6	C1018CR

**Female Keyed Shaft (A)**

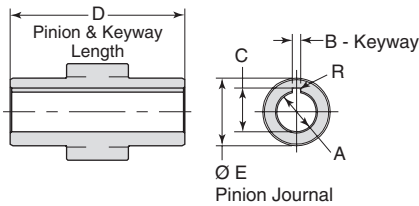

**Metric Female Keyed Shaft (G)**

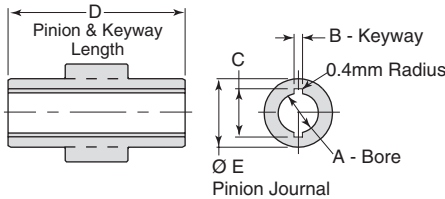

**Female Splined Shaft (D, L)**

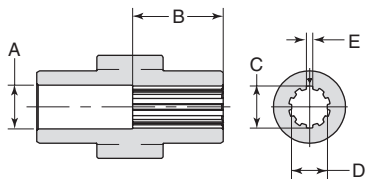

30° involute splined female shafts available for HTR300/600 (J). Consult factory.

**Male Splined Shaft (E, M)**

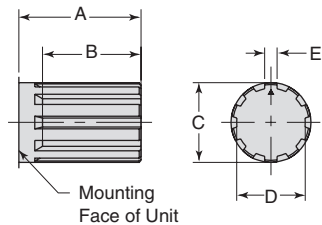

30° involute splined female shafts available for HTR300/600 (P,V). Consult factory.

Model	Option A*						Option G (DIN 6886)**				
	A <sup>†</sup>	B <sup>†</sup>	C <sup>†</sup>	D	E	R	A <sub>H7</sub>	B <sub>P9</sub>	C <sub>+0.04</sub>	D	E
HTR.9	.625	.187	.709	2.94	1.00	.030	16	5	20.6	74.6	25.4
HTR1.8	.626	.189	.719	2.94	1.00	.030	16	5	20.6	74.6	25.4
HTR3.7	.875	.187	.964	3.88	1.50	.015	22	6	27.6	98.4	38.1
HRT7.5	.876	.189	.974	3.88	1.50	.015	22	6	27.6	98.4	38.1
HTR5	1.250	.250	1.367	3.88	1.78	.030	32	10	38.6	98.4	44.5
HTR10	1.252	.252	1.377	3.88	1.78	.030	32	10	38.6	98.4	44.5
HTR15	2.000	.500	2.223	4.94	2.88	.030	48	14	55.6	125.4	73.0
HTR30	2.003	.502	2.233	4.94	2.88	.030	48	14	55.6	125.4	73.0
HTR22	2.000	.500	2.223	4.94	2.88	.030	48	14	55.6	125.4	73.0
HTR45	2.003	.502	2.233	4.94	2.88	.030	48	14	55.6	125.4	73.0
HTR75	2.750	.750	3.032	7.44	3.75	.030	72	20	81.8	188.9	95.2
HTR150	2.755	.753	3.042	7.44	3.75	.030	72	20	81.8	188.9	95.2
HTR300	5.000	1.250	5.366	11.94	6.50	.030	125	32	139.8	303.2	165.1
HTR600	5.005	1.252	5.376	11.94	6.50	.030	125	32	139.8	303.2	165.1

Model	Option D (10B Spline)*					Option L (DIN/ISO 14)**					No. of Splines
	A	B	C <sup>†</sup>	D <sup>†</sup>	E <sup>†</sup>	A	B	C	D	E	
HTR.9	.66	.63	.625	.538	.098	17	16	16	13	3.5	6
HTR1.8	.66	.63	.624	.537	.096	17	16	16	13	3.5	6
HTR3.7	.91	.88	.876	.753	.137	23	22	22	18	5	6
HRT7.5	.91	.88	.875	.752	.135	23	22	22	18	5	6
HTR5	1.16	1.3	1.125	.968	.176	29	29	28	23	6	6
HTR10	1.16	1.3	1.124	.967	.174	29	29	28	23	6	6
HTR15	2.03	2.00	2.000	1.720	.312	49	50	48	42	8	8
HTR30	2.03	2.00	1.998	1.718	.309	49	50	48	42	8	8
HTR22	2.03	2.00	2.000	1.720	.312	49	50	48	42	8	8
HTR45	2.03	2.00	1.998	1.718	.309	49	50	48	42	8	8
HTR75	3.03	3.00	3.000	2.580	.468	73	76	72	62	12	8
HTR150	3.03	3.00	2.998	2.578	.465	73	76	72	62	12	8

Model	Option E (10B Spline)*					Option M (DIN/ISO 14)**					No. of Splines
	A	B	C <sup>†</sup>	D <sup>†</sup>	E <sup>†</sup>	A	B	C	D	E	
HTR.9	1.34	.88	.873	.747	.134	33	22	22	18	5	6
HTR1.8	1.34	.88	.872	.742	.133	33	22	22	18	5	6
HTR3.7	1.91	1.25	1.248	1.069	.192	48	28	28	23	6	6
HRT7.5	1.91	1.25	1.246	1.064	.191	48	28	28	23	6	6
HTR5	2.65	1.75	1.748	1.499	.270	66	44	42	36	7	8
HTR10	2.65	1.75	1.746	1.494	.269	66	44	42	36	7	8
HTR15	3.41	2.25	2.247	1.928	.347	86	58	54	46	9	8
HTR30	3.41	2.25	2.245	1.923	.346	86	58	54	46	9	8
HTR22	3.41	2.25	2.247	1.928	.347	86	58	54	46	9	8
HTR45	3.41	2.25	2.245	1.923	.346	86	58	54	46	9	8
HTR75	4.53	3.00	2.997	2.573	.464	115	76	72	62	12	8
HTR150	4.53	3.00	2.995	2.568	.463	115	76	72	62	12	8

\* Dimensions in inches    \*\* Dimensions in mm    † Tolerance minimum and maximum

**A**  
 Rack & Pinion Actuators  
 HUB Series  
 LTR Series  
 HTR Series  
 M Series

**Port Sizes and Positions**

The standard port styles for HTR Series rotary actuators are SAE and BSP (parallel) port, but NPTF, flanged and metric port styles to DIN 3852/1 and ISO 6149/1 are also available. The relevant sizes of port for each model of rotary actuator are shown.

Ports will be supplied in position 1, as shown in the diagram, unless a different position is specified on the order. Ports are available in positions 2, 3, and 4 at no extra cost; position 5 is available as an extra cost option.

**Air Bleeds**

These may be fitted in end cap positions unoccupied by ports or cushions specify location in clear text.

**Port Locations**

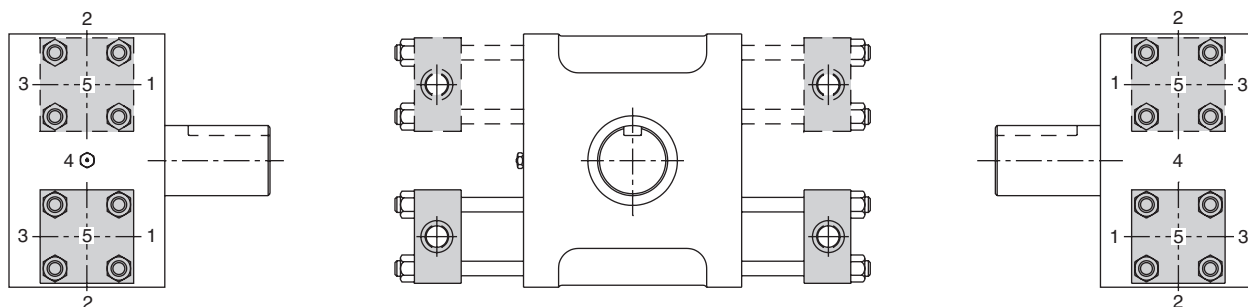

**NOTE:**

1. Port position 1 is standard.
2. Port position 2, 3 and 4 are standard options available at no additional cost.
3. Port position 5 is available at additional cost; not available with stroke adjusters.

**Port types and sizes**

Model	Standard SAE Straight Thread (1)	Code 61 SAE Flange (3)	NPT (2) BSPP (4)	Metric DIN (5)* or ISO (6)
HTR.9 HTR1.8	9/16 - 18 (SAE 6)	N/A	1/4	M14 x 1.5
HTR3.7 HTR7.5	9/16 - 18 (SAE 6)	N/A	1/4	M14 x 1.5
HTR5 HTR10	9/16 - 18 (SAE 6)	N/A	1/4	M14 x 1.5
HTR15 HTR30	3/4 - 16 (SAE 8)	N/A	1/2	M22 x 1.5
HTR22 HTR45	3/4 - 16 (SAE 8)	N/A	1/2	M22 x 1.5
HTR75 HTR150	11/16 - 12 (SAE 12)	3/4	3/4	M27 x 2
HTR300 HTR600	15/16 - 12 (SAE 16)	1	1	M33 x 2

\* DIN 3852/1

\*\* ISO 6149/1 (Not available with HTR.9 or HTR1.8)

**A**  
Rack & Pinion  
Actuators

HUB  
Series

LTR  
Series

HTR  
Series

M  
Series



**Seal Materials (V, W)**

Effective filtration is vital to the long life and satisfactory performance of a rotary actuator. If the piston seals of a rack and pinion rotary are worn or damaged, fluid which leaks past the piston will enter the gear housing. In the event of internal leakage into the gear housing, the pressure relief valve protects the shaft seal.

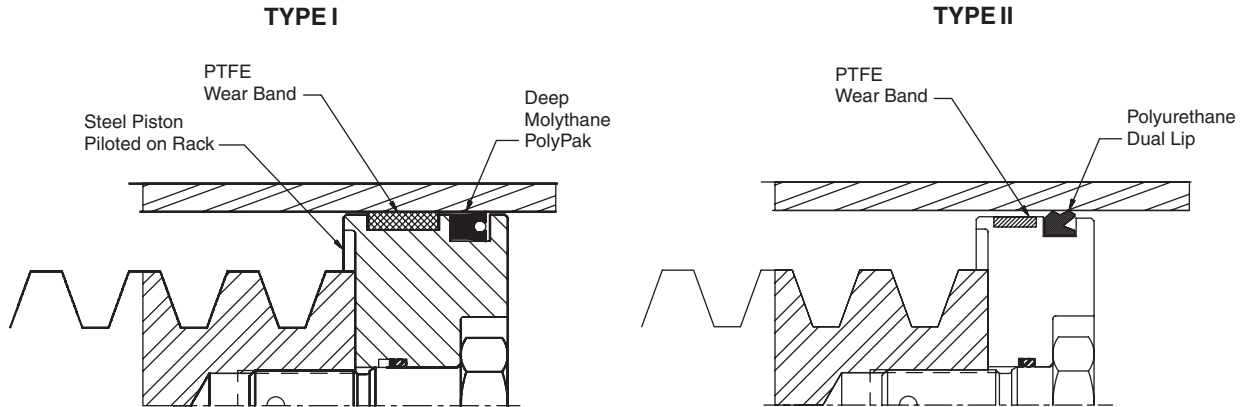

Seal class	Seal type	Wear ring type	Fluid medium	Temperature range	Pressure range	Filtration
Standard Type 1 *	Molythane PolyPak	Filled PTFE	General purpose, Petroleum-based fluids	-40°F to 180°F -40°C to 82°C	3000 PSI 207 bar	
Standard Type II **	Polyurethane Dual Lip	Filled PTFE	General purpose, petroleum-based fluids	-40°F to 180°F -40°C to 82°C	3000 PSI 207 bar	Minimum ISO Class 17/14 Cleanliness Level
Fluorocarbon (V)	Fluorocarbon	Filled PTFE	High temperature and/or synthetic fluids	-20°F to 250°F -29°C to 121°C	3000 PSI 207 bar	
Nitrile (W)	Carboxylated Nitrile	Filled PTFE	Water Glycol, high water content fluids	30°F to 180°F 0°C to 82°C	2000 PSI 138 bar	

\* Standard on HTR.9/1.8, 3.7/7.5 and 5/10  
 \*\* Standard on HTR15/30, 22/45, 75/150 and 3000

**Seal Kit Ordering Information**

- Standard units are equipped with nitrile seals.
- Optional seal compounds are available.
- See parts list for items contained in seal kits.

<b>PSK</b> Parker Seal Kit	—	<b>HTR.9</b> Base Model	<b>V</b>
			<b>Omit</b> = Nitrile Seals (Std)
			<b>V</b> = Fluorocarbon Seals
			<b>W</b> = Carboxylated Nitrile Piston Seals

**NOTE:** The seal kit is equipped with parts necessary to re-seal Design Series “A”, “B” or “C” HTR Series rotary actuators. If the actuator model number ends in C###, call factory for seal kit part number.

**A**

Rack & Pinion Actuators

HUB Series

LTR Series

HTR Series

M Series

**Parker Pneumatic**

**Proximity Switches**

**(Namco Cylinders or Balluff Cylinder Indicator Sensor)**

The inductive type proximity switch provides end of rotation indication. The non-contact probe senses the presence of the ferrous cushion spear and has no springs, plungers, cams or dynamic seals that can wear out or go out of adjustment. The switch is solid state and meets NEMA 1, 12 & 13 specifications. For ease of wiring the connector housing is rotatable through 304°. To rotate, lift the cover latch, position and release.

The switch make/break activation point may occur at 0.125" to ±0.125" from the end of stroke. Depending on the actuator size, this distance may cause activation at 2° to 15° from end of stroke.

The standard proximity switch controls 50-230 VAC/DC loads from 5 to 500 mA. The low 1.7 mA off-state leakage current can allow use for direct PLC input. The standard short circuit protection (SCP) protects the switch from a short in the load or line upon sensing such a condition (5 amp or greater current) by assuming a non-conductive mode. The fault condition must be corrected and the power removed to reset the switch preventing automatic restarts.

The low voltage DC switch is also available for use with 10-30 VDC. The switch is in a non-rotatable housing, but does incorporate the short circuit protection.

Both switches are equipped with two LEDs, "Ready" and "Target". The "Ready" LED is lit when power is applied and the cushion spear is not present. The "Target" LED will light and the "Ready" LED will go out when the switch is closed, indicating the presence of the cushion spear. Both LEDs flashing indicates a short circuit condition.

**Order proximity sensors separately. See Sensors section for specifications and ordering information.**

**NOTES:**

1. Available with or without cushions.
2. Not available with stroke adjusters.
3. Pressure rating: 3000 psi
4. Operating temperature: -4°F to 158°F
5. Specify switch type, orientation and voltage when ordering.
6. The low voltage DC switch is available in non-rotatable style only, consult representative for further information.

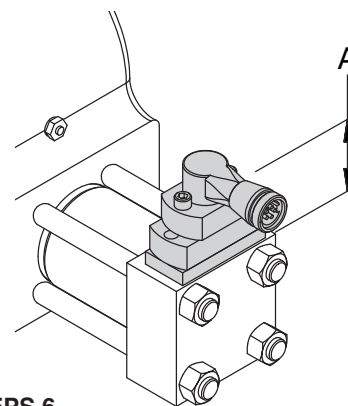

EPS 6

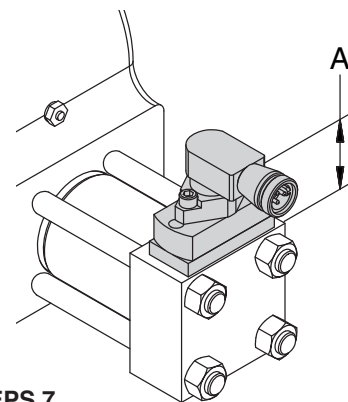

EPS 7

Model	A, inch (mm)
<b>EPS 6 &amp; 7</b>	
HTR.9	2.21 (56.1)
HTR1.8	
HTR3.7	2.70 (68.6)
HTR7.5	
HTR5	2.70 (68.6)
HTR10	
HTR15	2.64 (67.0)
HTR30	
HTR22	2.37 (60.2)
HTR45	
HTR75	1.87 (47.5)
HTR150	
HTR300	3.45 (87.6)
HTR600	

**Feedback Packages**

Feedback packages available for use with HTR Series rotary actuators include:

- Precision feedback potentiometer (J)
- Precision resolver feedback (H)
- Linear potentiometer feedback (Oildyne Teknar)
- LDT feedback (MTS Temposonics)

The feedback potentiometer (J) and resolver feedback (H) may be ordered as part of the model code. The other options must be ordered separately as specials. See Sensors section for specifications.

